

Operating & Installation Manual

(ZH1.5kw wind turbine system)

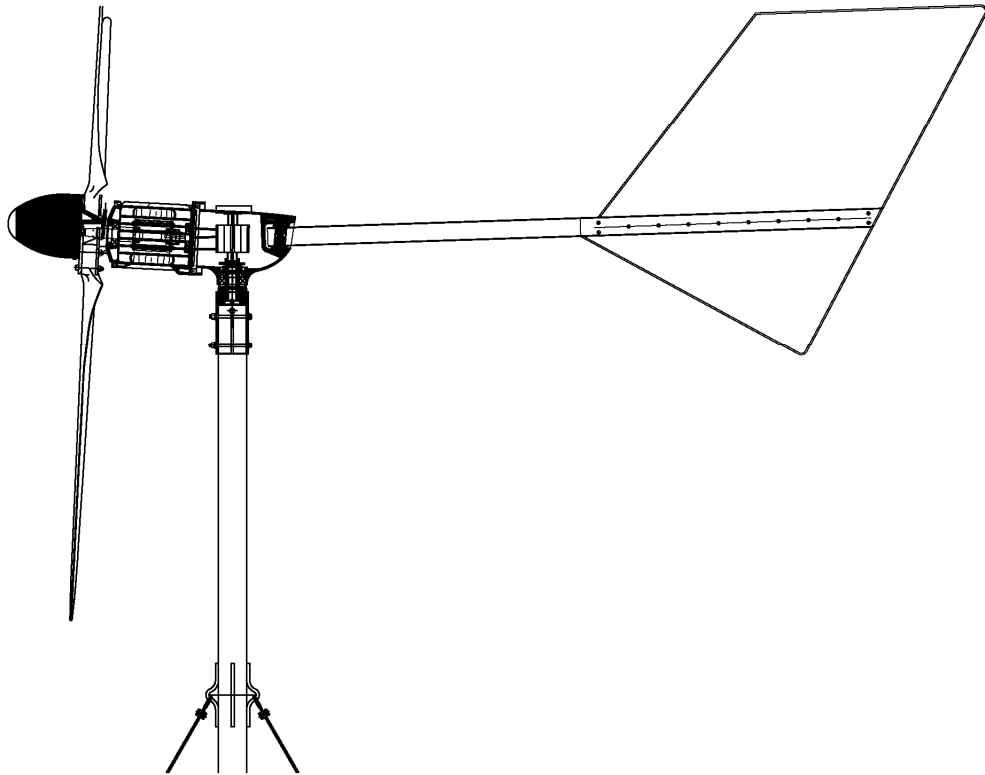

Company Name: YUEQING ZONHAN WINDPOWER CO.,LTD.

Address: NO.195,Chengxi Road,Yuecheng,Yueqing,Zhejiang,P.R.China

Zip Code: 325600

Tel: 86-577-62529820

Fax: 86-577-62529821

E-mail: Info@windgenerator.cn

****Please read carefully before use ****

1. Wind Turbine

Uses wind energy to generate electricity to charge storage batteries or to connect directly to an inverter.

The inverter converts the DC (Direct Current) from the wind turbine controller and/or the batteries in to AC (Alternating Current). The AC electricity produced is then feed into the properties mains supply to reduce power taken from the utility supplier.

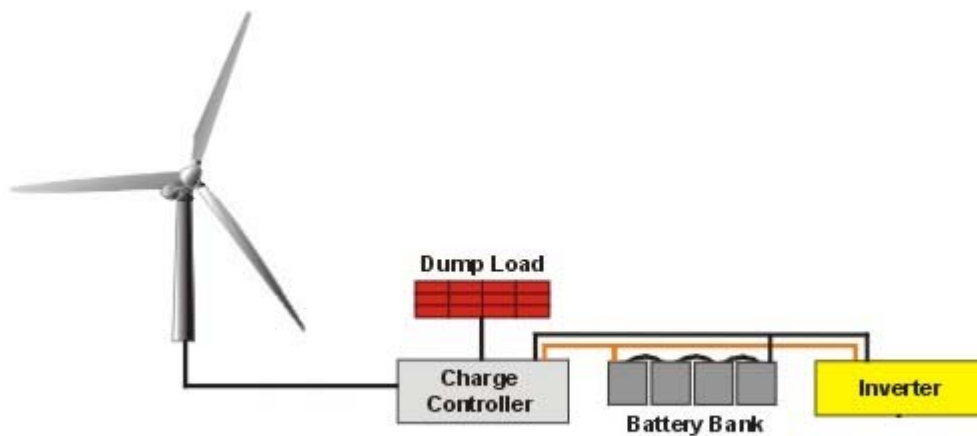

2. Components and main technical performance

The turbine is comprised of: Nose Cone, Blades*3PCS, Hub, Generator, Rotor, Tail Rod, Tail Vane, Tower & Accessory.

Rotor Diameter	3.2mtrs
Material and number of the blades	3 x reinforced fiber glass
Rated power/maximum power	1.5kW / 1.8 kW
Rated wind speed	9m/s

Startup wind speed	2.5 m/s
Working wind speed	3-25 m/s
maximum wind speed	50 m/s
Working voltage	DC24/48V (higher voltage optional)
Generator type	Three phase, permanent magnet
Charging	Constant voltage
Speed regulation method	Autofurl
Tower height	12mtrs
Life time	10-15years

3. Preparation

- 3.1 If batteries are used, carry out charging according to the manufacturer's recommendations.
- 3.2 Unpack and check the turbine parts.
- 3.3 Select an open flat area for installing the wind turbine and away from any trees
or other buildings.
- 3.4 To avoid power loss, the distance between the wind turbine and batteries should
be kept as short as possible, preferably less than 30mtrs.

4. Installation Specification of Guyed Tower

4.1 Choosing Installation Sites

The wind turbine should be erected high and far away from obstacles as possible in order to get relatively high wind speed. Meanwhile soil quality of installation location should be taken into consideration. Loose sands, uneven or

easily influenced by weather condition areas should be excluded from installing the wind turbine. When selecting the locations, it's necessary to consider the distance between generator and pile. The shorter the distance is, the less cable would be used. As a result, less energy waste would be produced during the transmission. While under the circumstances of longer distance, it's better to use much thicker standard cable for the transmission.

4.2 Layout of Tower, Base & Anchor (as shown in the following spec)

Model	1500W
Semi diameter (m)	3.0
Size of central base(m) (long*wide*deep)	0.5*0.5*0.4
Size of side base (m) (long*wide*deep)	0.4*0.4*0.3

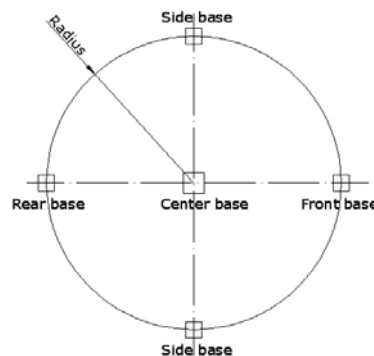

Figure 1: layout of concrete base

4.3 Special attention should be paid to the following when laying out the base and anchor:

- 4.3.1 Connecting line of two side anchors should be in parallel with the connection of two pinholes on the tail edge.
- 4.3.2 Make sure the side of tail edge with screw thread face the anchor.
- 4.3.3 The height of anchor should be consistent with the height of tower base.

Therefore, the pulling force between fixed cable wires should be balanced for the sake of easy adjustment. Otherwise, too tight or too loose fastening pull

will lead to the curvature or even breakdown of tower while erecting the tower.

4.4 Concrete the Foundation of Base as well as Anchor and Install Tower Base

4.4.1 Follow the layout of the above step, dig the concrete construction holes.

Please refer to the chart one above for the size of the holes.

4.4.2 C25 concrete should be available. Four anchor bolts will be installed according to the holes on the base. Attention to make sure they are consistent with base holes. Fix the base with bolts on the cement done before (as shown in the graph 2).

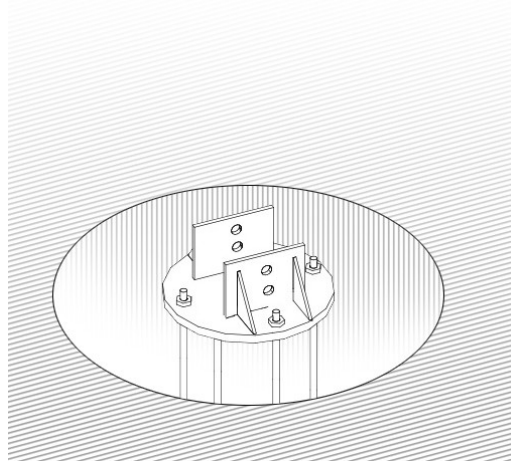

4.5 Annular anchors need to be deposited 60° to 80° along the base direction and check the distance between the four hooks of the anchors and the center of the base. Four anchors should be horizontal (as shown in the graph 3).

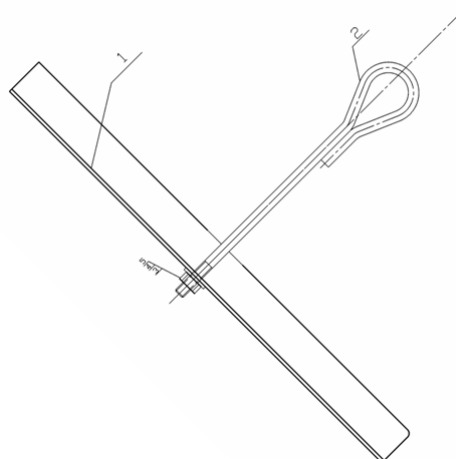

4.6 Assembly of the tower and wind turbine

4.6.1 First, insert the main section of tower into base, then insert the axis pin into base and insert the split pin.

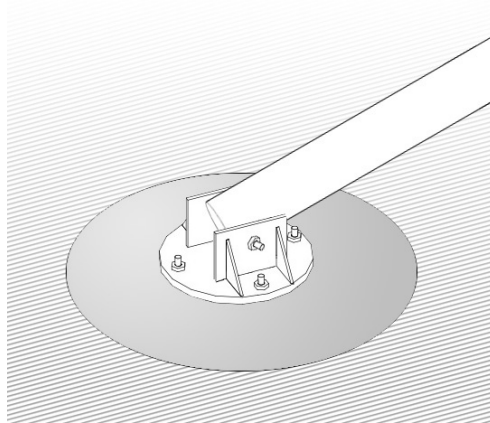

4.6.2 Connect each section of tower one by one, place the tower on the supporting stand after assembly.

4.6.3 Rip the generator and dogvane cables into the tower, and elicit the cables from the main section of tower, near the tail edge.

4.6.4 Fix the running flange and tower flange by bolts. Hoist it by equipments such as pulleys, chain block etc. Pay attention that the generator axis should be faced upward in order to install the blades.

5. Installation procedure

5.1 It is best to choose a clear dry day with very little or no wind.

5.2 First insert the electric cable into the tower starting from the bottom and pull the cable out of the top of the tower about 300mm and tie off with a temporary knot.

5.3 Mount the wind generator main body to the top of the tower. Connect the 3 electric cables from the tower to the turbine using a waterproof terminal block. Insert the tower into the sleeve barrel, and fix it with 2sets M14 bolts, spring washers and nuts.

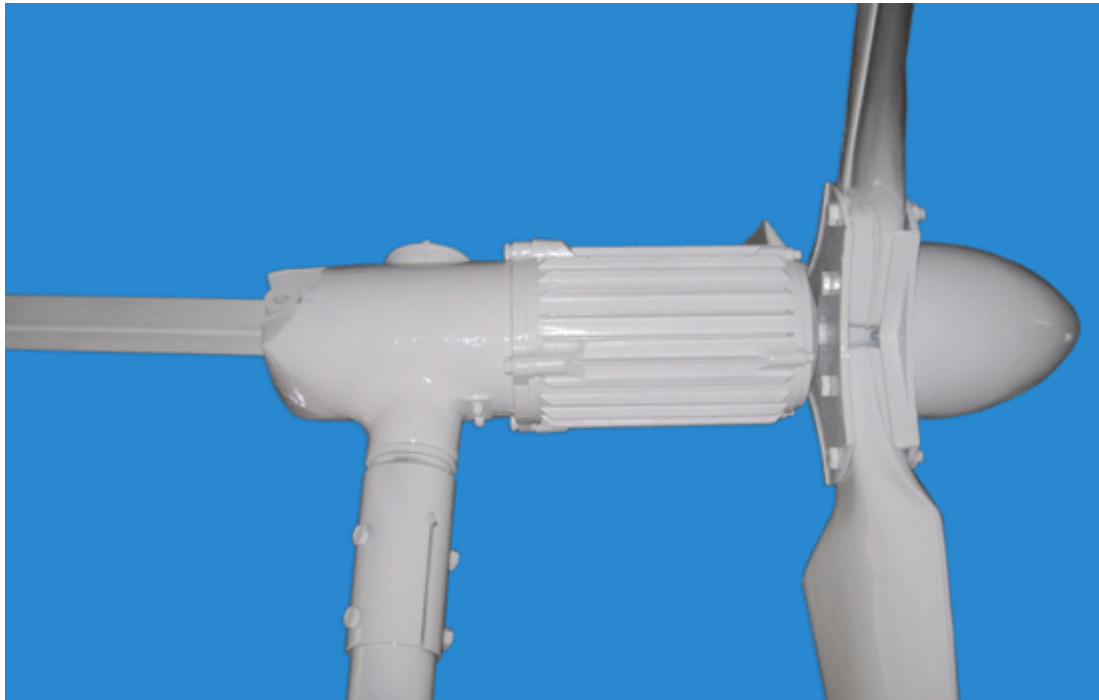

5.4 Assemble the tail rod and fix to the rotor body by a stainless steel pin roll. The Pin roll could be pull out by a M8 bolt.



5.5 Fix the tail vane by M10 screws, washers.

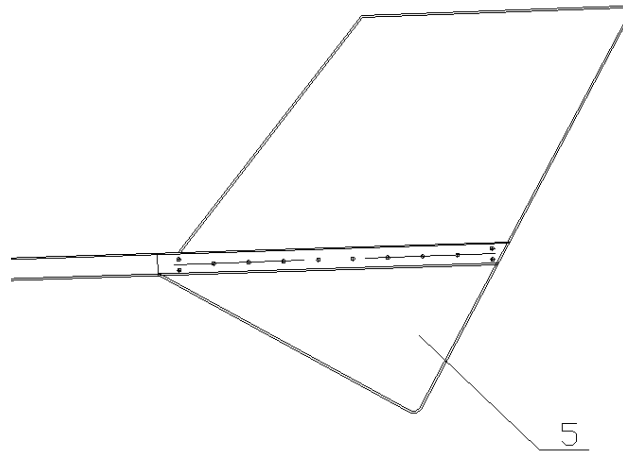

5.6 Before leaving the factory, every set blades had been assembled and balanced. When reassembling the rotor, please check the marks on the parts, and ensure they are match their former positions (A-A,B-B,C-C) , then using the M12×100 screws, washers Tighten down the nuts to a torque of 40-45 N.m

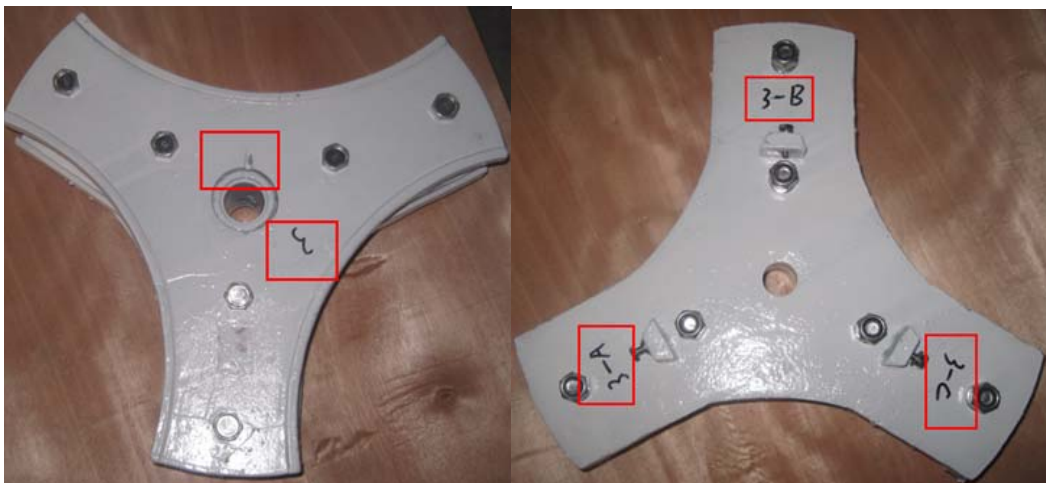

5.7 The blades should be kept horizontal on the ground when installing the hub;



Set up the blades is absolutely prohibited if the bolts haven't been tightened completely. It will influence the balancing of one set blades.



5.8 Lift the blades about 1.5m from the ground. Assemble the blades on the generator shaft, use the flat washers, spring washers, the self-locking nuts and tighten firmly.

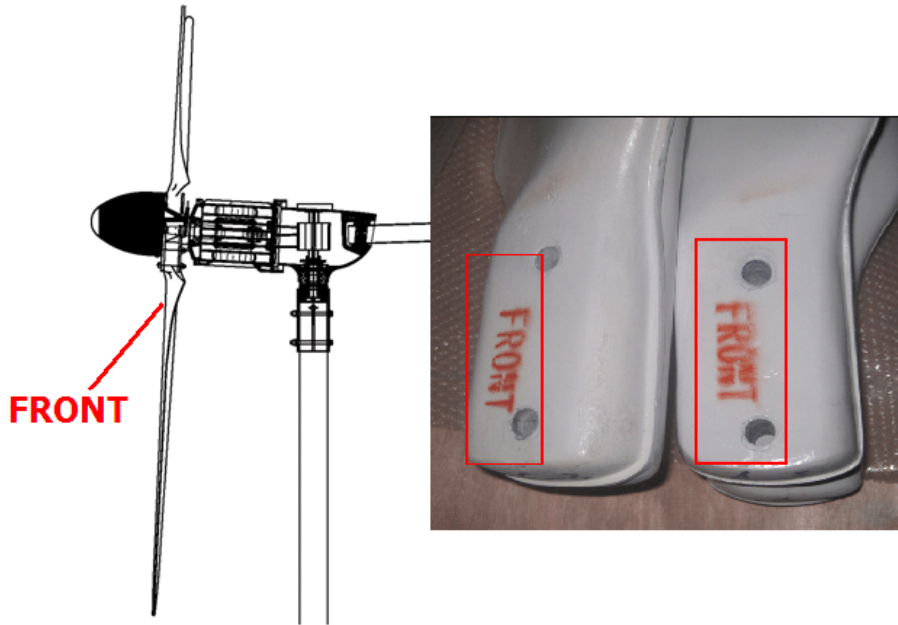

5.9 Fit the nose cone to the hub of the rotor using the M6 screws, spring washers and flat washers.

5.10 Check all parts carefully to confirm all connections, nuts and screws are fully fitted.

5.11 Connect the batteries in series, the two ends connectors are "+" and "-" respectively. The connecting wires between batteries and the input & output should be 6mm², "+" is marked red and "-" is marked by black (or yellow, or blue). All connectors should use wire connection clips, ensure every connection is firmly tightened. In order to prevent acid corrosion of the connecting clips and terminals, spread a layer of protection grease on each connection.

5.12 Connect the red cable "+" from the batteries to the "+" connector on the controller & Inverter; then, connect the black cable "-" from the batteries to the "-" connector on the controller & Inverter. Connectors must be tightened firmly and ensure a good connection.

5.13 Connect the three phase output cables from the generator to the connectors on the controller & Inverter respectively.

5.14 There are two outputs: (a) DC output; (b) AC output. One for low voltage DC and **220VAC**. When using the **AC220** output, please take care to avoid

electric shocks

6. Application notices

6.1 Application principles

The wind turbine should be installed in an open and flat area, where no obstructions nearby and in an area where you can get the maximum wind.

6.2 Electricity generated off – grid is used from the batteries when there is no wind; when there is sufficient wind, the generator will charge the batteries. If the batteries become discharged, they should be recharged, especially if using lead-acid batteries. Over discharging or discharging will seriously affect the working life of the batteries. Users should regulate the consuming capacity of the electricity according to local wind conditions and the electricity capacity generated by the wind generator.

6.3 After full wave rectification, the three phase AC generated by wind generator is converted to DC power, usually DC48v-DC492v, in order to obtain full efficiency of the system, the voltage of the batteries should be equal to the DC voltage of the wind generator.

6.4 The input DC voltage of the inverter should be equal to the working voltage of the wind generator.

7. Safety regulations

7.1 It is not allowed that the wind generator rotating without any loose continually, or running at a very high rotating speed continually.

7.2 Check the tower regularly, if there are any signs of loosening, it should be tighten in immediately, to prevent any damage to the wind turbine.

7.3 When rotation speed of the rotor is high, people must not stay under the wind turbine.

7.4 If vibrations or it becomes noisy during operation, stop the wind turbine and check the reasons.

7.5 The power supply from the wind generator should be independent and not used with other power supply lines. DC power supply is safe and economic

for illumination; for domestic electric appliances, the AC power supply from inverter should be used. It is suggested that the connector of the refrigerator should insert in the special plug seat which has the function of time lapse.

7.6 When connect the electricity from the wind generator, the battery lines must be first connected to the controller & dump load, then connect the three wires from the generator to the controller & inverter. When disconnecting the electric line from the wind generator, the three wires must be disconnected first from the controller & inverter, then disconnect the two wires from the batteries to the controller & inverter.

7.7 The "open & close" switch on the controller & inverter should keep at "open" position in normal operation. Only when the batteries are fully charged or to protect the turbine from very high winds, the switch can be in the "close" position. **DO NOT** move the switch when wind is very high and blades is running at high speed, turn the switch to the "close" position when blades is running slowly.

7.8 The batteries should be stored in a well ventilated area to ensure that any gases from charging and discharging can escape it should also not get excessively hot or cold.

7.9 Keeping the blades in balance and eliminate vibration

When the blades loose balance caused by damage and create strong vibration, the wind generator must be stopped and checked, until the problem is eliminated.

8. Maintenance of wind turbine

The wind turbine has only one moving part, the turbine its self. This is basically a large motor with blades on it to collect the wind. These items are very reliable and need a simple inspection once a year. After 3 years turbine needs an overhaul as following:

a. Examine the surface of the blades carefully. If there is any air cauterization place, please repair.

- b. Check all the bolts, lay antiseptic on the cauterization place.
- c. Check the lubricate status of the generator, keep it in good state.
- d. Check the erodibility of the surface and the inside parts of the wind turbine.
- e. The tightness degree of the steel wire should also be checked.

This procedure is a general overhaul in the warranty service period. And this check will not cost much. The big models may need crane equipment in the checking.

The 5 and 10 years' overhaul needs to disassemble the wind turbine. Mainly check the damageable parts, such as the bearing, bolts, plumbago brush, and replace if needed.

If the wind turbine is working under the following circumstance for long time, some parts will be easily damaged:

- 1. Coastal area. The out parts such as the surface, the tower, may be cauterized.
- 2. High temperature area. The cable may be aging much more quickly.
- 3. Low temperature area. The cable also maybe aging quickly. The ice will attach on the blades easily and cause the imbalance.

9. Elimination of breakdown

The wind generator is designed and manufactured to a high standard and to minimize maintenance, if the installation and operation are correct, breakdown should not happen under normal conditions. **In case of breakdown, see the following table.**

Breakdown	Reason	Remedy
Wind generator vibrating excessively	<ul style="list-style-type: none"> 1. Steel cables have become loose. 2. Blade fixing bolts are loose. 3. Blades are damaged. 4. Ices on the surface of the blades has cause the unbalance. 	<ul style="list-style-type: none"> 1. Adjust the steel cables. 2. Tighten the loose bolts 3. Replace the defective blade/s and rebalance. 4. Remove the ice.
Direction regulating is ineffective	<ul style="list-style-type: none"> 1. There is too much grease and dirt in the rotating body. 2. The turning place is damaged by the outside power. 	<ul style="list-style-type: none"> 1. Clean away the grease and dirt and re-grease. 2. Recover and correct

	<ol style="list-style-type: none"> The clearance between vertical shaft and sleeve is too small, or there is no axial clearance. 	<p>the deformation.</p> <ol style="list-style-type: none"> Adjust the clearance to the required amount.
High noise	<ol style="list-style-type: none"> Fixed parts have become loose Generator bearing has become loose from its seat. Generator bearing is damaged Wind rotor is rubbing on other parts. The stator and rotor is rubbing badly, or the bearing is broken. 	<ol style="list-style-type: none"> Lower the wind turbine, check all fixed parts and take measurements against the specification. . Locate the loose bearing and either tighten or replace, or find the problem and correct. Replace the damaged bearing. Check and eliminate the trouble. Change the bearing or eliminate the rubbing.
The rotating speed of the wind rotor has reduced.	<ol style="list-style-type: none"> Blade pitch control is wrong. Stator winding or output circuit has short circuited. Switch is set at "close" position: The stator and rotor is rubbing heavily. 	<ol style="list-style-type: none"> Check and eliminate the problem and lubricate. Find short circuit position, split the lines and isolate. Set switch to the "open" position. Disassemble, check and fix the problem.
The output voltage of the generator is low	<ol style="list-style-type: none"> The rotating speed of the generator is low. Permanent magnet rotor has lost its magnetism. The conductivity of the connection between slip ring and output circuit is low. There is short circuit in rectifier. Circuit line is too long, or the cable diameter is too small. A short circuit in the 3-phase rotor winding. 	<ol style="list-style-type: none"> Check that the rotor is running smoothly. Charge the magnet, or change the generator rotor. Clean the slip ring and contact points to reduce resistance. Replace. Decrease the circuit length or increase the diameter of the cable, to reduce loss. Find the short circuit

		and insulate it
There is no AC output from the Generator	<ol style="list-style-type: none"> 1. A break in the AC circuit from the generator, or the fuse has blown. 2. A break in the output Cable. 3. Stator winding is burnt out. 	<ol style="list-style-type: none"> 1. Check the fuse replace if blown. Check the cables for a break and reconnect. 2. Find the beak point and reconnect the cable. 3. Disassemble and repair
AC output normal, but there is not DC output current	<ol style="list-style-type: none"> 1. DC fuse has blown. 2. DC output circuit is broken. 3. Rectifier is damaged. 	<ol style="list-style-type: none"> 1. Replace. 2. Find the beak and reconnect the cables. 3. Replace.
Output capacity of the batteries is insufficient	<ol style="list-style-type: none"> 1. Output voltage of the generator is too low, or no electricity is being generated 2. The battery connections have corroded. 3. Battery failure 	<ol style="list-style-type: none"> 1. Check the rotor and moving parts are running freely. 2. Clean the connectors grease and ensure good connection. 3. Replace the damaged battery