

YSL10 Solar Powered Obstruction Light

The solar panel comes with YSL10 provides power supply to the light, which makes YSL10 a self-contained and care-free light unit. Also, with the solar function, the light is easy to deploy to almost any condition and any emergency case. Robust body built and surface coating provides good protection against harsh environments.

it also can use in Offshore gas & oil platform

YSL10 is equipped with an 8Ah NiMH rechargeable battery which could power the light up to 20 days when the weather is cloudy & rainy. NiMH battery is also a clean power source with no pollution. The NiMH battery is also easy to find almost anywhere.

YSL10 can increase the synchronous line of realizing multi YSL10 synchronous. Can increase the alarm output. YSL10 is also available with an optional on/off switch for storing and protect battery from overcharge and over-discharging.

Features

- Ultra-light LEDs, energy saving
- Self-contained without outside power supply
- Maximum visibility distance 4 KM
- Once fully charged, it can work for up to 200 hours
- Auto-off after being packed for 18 hours

APPLICATIONS

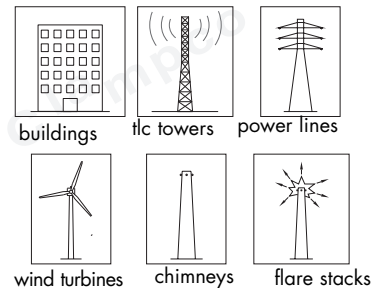

Specifications

LIGHT OUT-PUT	
Intensity	FLASHING ● Red: >10cd ● Green:>20cd ● Yellow: >10cd ○ White:>25cd ● Blue:>5cd STEADY ● Red: >4cd ● Green: >8cd ● Yellow: >4cd ○ White:>10cd ● Blue:>2cd
Nominal Night Range	>4 KM
LED Color Available	Red, Green, Yellow, White, Blue
Vertical Divergence	10 Degree
Horizontal Out-put	360 Degree
Illumination	Ultra-bright LEDs
LED Lifespan	100,000 Hours

OPERATION	
Autonomy	Flashing : 200 Hours / Steady : 100 Hours
On & Off Level	70/100 Lux
Flash Pattern	40FPM default (can be preprogrammed to a specified flashing rate upon customer request)

POWER SUPPLY	
Power Source	Solar module, mono-crystalline silicon
Solar Efficiency	13.5%
Max. Power Out-put	1.8 Watts
Battery Type	High-efficiency NiMH rechargeable battery
Battery Capacity	8 AH / 3.6V
Battery Replacement	Yes, replaceable

MECHANICAL STRUCTURE	
Lens	Polycarbonate, UV Stabilize
Body	Die-casting Aluminum
Water-proof	IP67
Weight	3.5 KG
Temperature Range	-40C° ~ +55C°
Dimensions	215.5mm H, 226mm Diameter
Warranty	5 years for light 2 years for NiMH battery

Note: when the light is in storage, please put it outside to charge the battery every 3 months

YUAN SHENG AMS mounting kit : Ordering Code

Series	Vertical tower leg diameter range	Horizontal tower leg diameter range
AMS3080	30-80mm	30-80mm
AMS30150	30-150mm	30-80mm

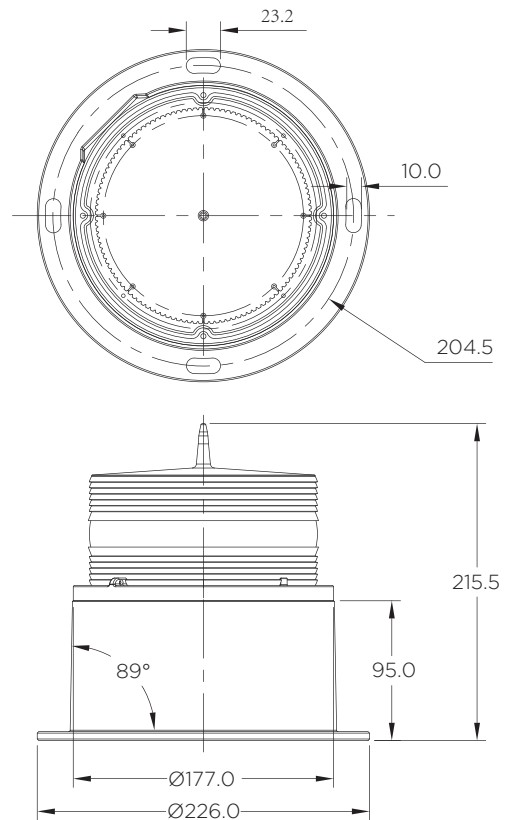

Installation

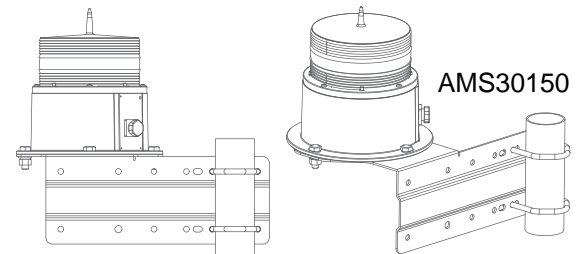
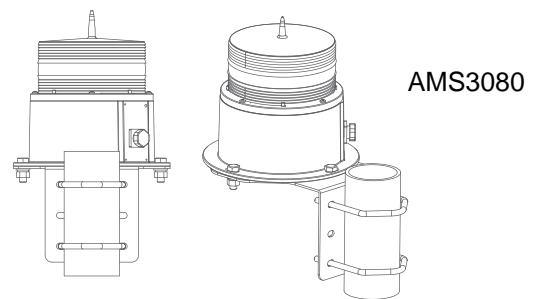

YSL10D Double Solar powered Aviation obstruction light

Based on Yuansheng YSLL10, YSL10D is a "twin" - model which can be working synchronization. An internal solar panel comes with each single light of YSL10D, provides power supply to the light, which makes YSL10D a self-contained and care-free light unit. Also, with the solar function, the light is easy to deploy to almost any condition and any emergency case. Robust body built and surface coating provides good protection against harsh environments.

YSL10D is equipped with an 8Ah NiMH rechargeable battery for each single which could power the light up to 20 days in flashing mode when the weather is cloudy & rainy. NiMH battery is also a clean power source with no pollution. The NiMH battery is also easy to find almost anywhere.

Features

- Ultra-Bright LED, energy saving
- Self-contained without outside power supply
- Maximum visibility distance 4 KM
- Once fully charged, it can work for up to 200hours
- Auto-off after being packed for 18 hours
- Either single light fails will not affect the other normal working

Application

- High-rise building marking
- Telecom tower marking
- Road obstruction marking
- Navigation aid
- Port, dock entrance & walkway
- Buoy marking
- Offshore gas & oil platform

