

SR11

First class pyranometer

SR11 is a high accuracy solar radiation sensor. SR11 first class pyranometer complies with the first class specifications of the ISO 9060 standard and the WMO Guide. It is the preferred instrument for outdoor PV system performance monitoring, according to the ASTM E2848 standard.



Figure 1 SR11 first class pyranometer



Figure 2 SR11 pyranometer in greenhouse application

Introduction

SR11 is a solar radiation sensor that is applied in general high accuracy observations. It measures the solar radiation received by a plane surface from a 180° field of view angle. This quantity, expressed in W/m^2 , is called “hemispherical” solar radiation. SR11 pyranometer can be employed outdoors under the sun, as well as indoors with lamp-based solar simulators. Its orientation depends on the application and may be horizontal, tilted (for plane of array radiation) or inverted (for reflected radiation).

PV system performance monitoring

The ASTM E2848 “Standard Test Method for Reporting Photovoltaic Non-Concentrator System Performance” (issued end 2011) confirms that a pyranometer is the preferred instrument for PV system performance monitoring. SR11 complies with the requirements of this standard.

Improved measurement accuracy

Calibration of SR11 pyranometer has been improved; our latest calibration method results in an uncertainty of the sensitivity of 1.8 %, compared to typical uncertainties of higher than 2.8 % for this pyranometer class.

Uncertainty evaluation

The uncertainty of a measurement under outdoor conditions depends on many factors. Guidelines for uncertainty evaluation according to the “Guide to Expression of Uncertainty in Measurement” (GUM) can be found in our manuals. We provide spreadsheets to assist in the process of uncertainty evaluation of your measurement.

Suggested use

- PV system performance monitoring
- general solar resource monitoring
- indoor simulated solar testing
- meteorological networks

SR11 design

SR11 first class pyranometer employs a thermal sensor with black coating, two glass domes and an anodised aluminium body.

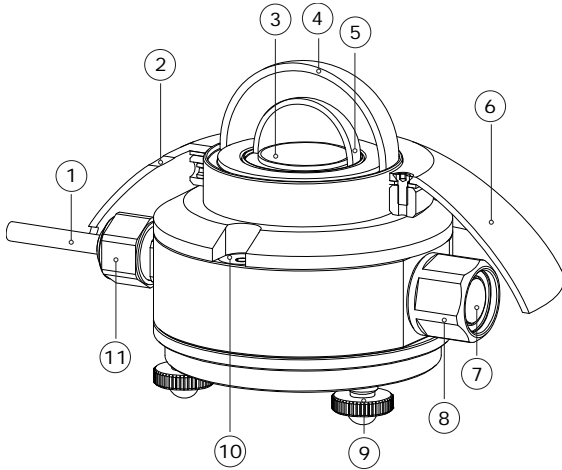

Figure 3 overview of SR11:

(1) cable, (2) opening for fixation of sun screen, (3) thermal sensor with black coating, (4) outer dome, (5) inner dome, (6) sun screen, (7) humidity indicator, (8) desiccant holder, (9) levelling feet, (10) bubble level, (11) cable gland

Use as sunshine duration sensor

WMO has approved the “pyranometric method” to calculate sunshine duration from pyranometer measurements in WMO-No. 8, Guide to Meteorological Instruments and Methods of Observation. This implies that SR11 may be used, in combination with appropriate software, to estimate sunshine duration. This is much more cost-effective than using a dedicated sunshine duration sensor. Ask for our application note.

Choosing the right instrument

Pyranometers are subject to classification in three classes according to ISO 9060. From second class to first class and from first class to secondary standard, achievable accuracy improves by a factor 2. Measurement accuracy does not only depend on instrument properties, but also on measurement conditions. A very accurate instrument will quickly underperform without a regular schedule of maintenance. Our pyranometer [selection guide](#) assists you in choosing the right instrument. Whatever your application is: Hukseflux offers the highest accuracy in every class at the most attractive price level.

SR11 specifications

Measurand	hemispherical solar radiation
ISO classification	first class pyranometer
Calibration uncertainty	< 1.8 % (k = 2)
Calibration traceability	to WRR
Spectral range (50 % transmission points)	300 to 2800 x 10 ⁻⁹ m
Sensitivity (nominal)	15 x 10 ⁻⁶ V/(W/m ²)
Rated operating temperature range	-40 to +80 °C
Temperature response	< ± 2 % (-10 to +40 °C)
Standard cable length	5 m

Options

- longer cable, in multiples of 5 metres
- internal temperature sensor

See also

- [SR11-TR](#) first class pyranometer with 4-20 mA transmitter
- [SR12](#) first class pyranometer for solar energy test applications
- alternative instrument: [SR20](#) for higher accuracy measurements
- view our complete [product range of solar sensors](#)

Standards

Applicable instrument classification standards are ISO 9060 and WMO-No. 8. Calibration is according to ISO 9847. PV related standards are ASTM E2848 and IEC 61724.

About Hukseflux

Hukseflux Thermal Sensors, founded in 1993, aims to advance thermal measurement. We offer a complete range of sensors and systems for measuring heat flux, solar radiation and thermal conductivity. We also provide consultancy and services such as performing measurements and designing instrumentation according to customer requirements. Customers are served through the main office in Delft in the Netherlands, and locally owned representations in the USA, China and Japan.

Interested in this product?
E-mail us at: info@hukseflux.com